

Letters

Nucleation and growth of cadmium films

In the course of studying the electron transport properties (electrical resistivity, Hall effect and thermoelectric power) of cadmium films deposited onto glass substrates, it was observed that it was extremely difficult to obtain coherent cadmium films in the conventional way. Initial difficulties were overcome by using a jet source with slits above it (Fig. 1) instead of evaporating cadmium from a helix or a crucible. Another difficulty was encountered when we tried to measure the thicknesses of the films using FEKO and Fizeau interferometers. The reflectivity of the films was extremely poor, even when they were coated with thick silver and other materials which produce reflecting films. We then intended to study the surface texture and the growth process of the films, to justify our proposition of a highly diffuse reflection from an "abnormal" Cd-film surface which might be responsible for the poor reflectivity mentioned above.

The films were deposited onto a cleaned glass substrate at a system pressure of $\sim 10^{-6}$ Torr, using pure cadmium (99.999%, Johnson and Matthey, UK) as evaporating material. The growth and structure were studied by scanning and transmission electron microscopy. The films were removed

from the substrate by chemical means for observation by TEM.

Resistivity (ρ)–temperature (T) plots indicated a non-reversible behaviour of the room temperature-deposited films when subjected to thermal cycling followed by prolonged annealing. However, when the films were deposited at a substrate temperature of 100°C , the ρ – T behaviour was reversible, therefore we studied the cadmium films deposited at 100°C in order to obtain coherent films. Our observation corroborates that made by Komnik and Bukhshtab [1], Palatnik and Koserich [2], and Palatnik and Komnik [3] that the depositions should be made at substrate temperature, T_s ($\frac{1}{3} T_m < T_s < \frac{2}{3} T_m$ where T_m is the melting point of the bulk material) to facilitate vapour \rightarrow solid condensation. The $\frac{1}{3} T_m$ limit is essentially that below which the adatoms do not have sufficient mobility to produce ordered structure. The significance of the $\frac{2}{3} T_m$ limit was discussed in detail by Komnik and Bukhshtab [1].

Fig. 2 shows a scanning electron micrograph of a cadmium film ($\sim 1000 \text{ \AA}$) deposited at 100°C . The picture shows a very rough surface consisting of numerous hills and valleys, clearly suggesting that the growth of cadmium films is altogether quite different from conventional film growth. Individual hills have grown perpendicular to the plane of the substrate surface rather than coalescing with each other to produce uniform texture. The hills are inter-connected by the numerous ridges near the bottom of the individual hills thus producing a continuous film. It is interesting to note that the heights of most of the hills are nearly the same. Fig. 3 shows a TEM of the same film which is chemically etched to $\sim 200 \text{ \AA}$. The micrograph clearly reveals the ridges which join together to form the summit of the hills.

Fig. 4 indicates the typical behaviour where it can be seen that even at the very initial stage of nucleation the cadmium nucleates at some specific parts of the substrate and tends to grow in the form of hills perpendicular to the substrate plane. At this point it is worthwhile to note that cadmium films do not follow the conventional growth pattern as obtained in gold or silver films where monolayers are followed by overlayers. In cadmium the

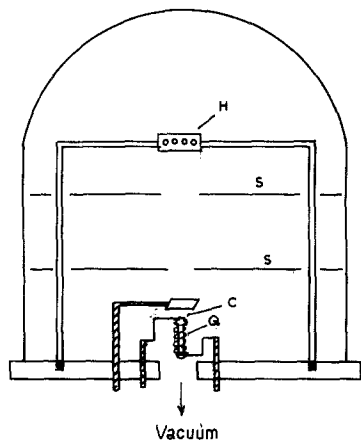

Figure 1 Schematic diagram of the evaporation chamber. H, specimen holder; S, stainless steel sheets with slits at the centre; C, mild steel cap; Q, quartz tube.

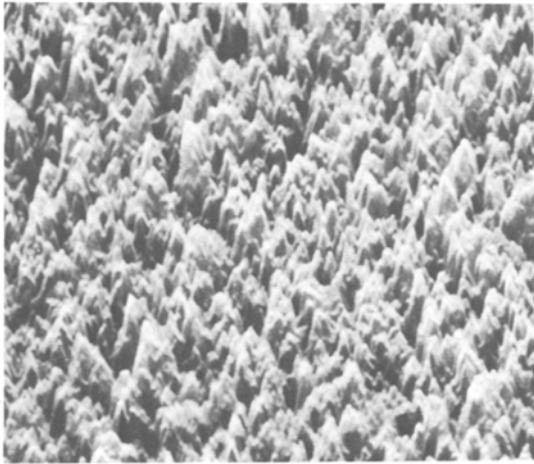

Figure 2 Scanning electron micrograph (Y-Z, 45° tilt) of the cadmium film (~ 1000 Å) deposited at 100° C (X 2800).

atoms tend to cluster at some parts of the substrate with the formation of thick adlayers leaving other parts entirely devoid of any deposition. This is typical behaviour of a high interaction system. Thus even when one wishes to deposit very thin films (say 5 or 10 Å), a substrate having localized thick layers at some parts of the substrate leaving most of the substrate surface devoid of any condensation of Cd-atoms, is obtained.

It is known that the thin-film deposition system can be generally classified on the basis of (1) the strength of the interaction between atoms of the deposit and the substrate, relative to the interaction between atoms of the deposits themselves, and (2) the lattice match between the substrate and the film. Cadmium is known to show very low pair-interaction energies in the smallest clusters. By virtue of this, the interaction between substrate and single atom can play a major role in the deposition process indicating possible substantial absorption in traps on the substrate. Cadmium seems to have a large nucleation barrier so that the film consists of only a few but large aggregates. The aggregates must be large because their minimum possible size is large, and they are relatively few in number because the nucleation frequency is relatively small. As the cadmium films with large islands grow, the island structure is seen to persist up to relatively high average film thicknesses and when the islands have coalesced to form a continuous film, the effect of nucleation is still visible rendering a coarse surface to the film.

Acknowledgement

The authors wish to thank Professor A. K. Barua for his keen interest in the problem.

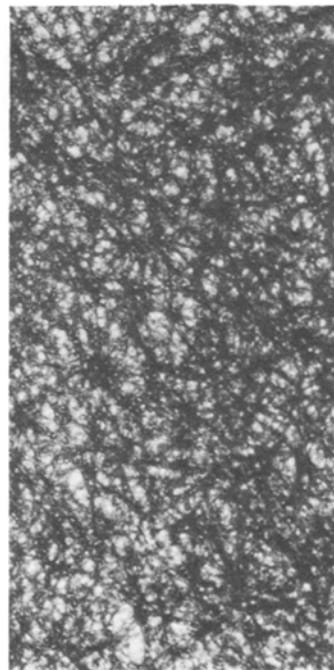
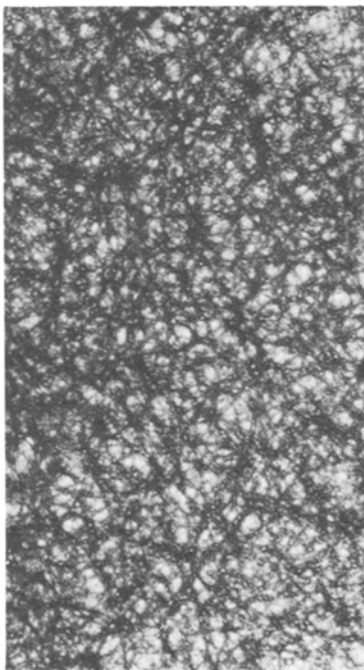

Figure 3 Transmission electron micrograph of the cadmium film (~ 1000 Å) deposited at 100° C and etched to ~ 200 Å (X 33 500).

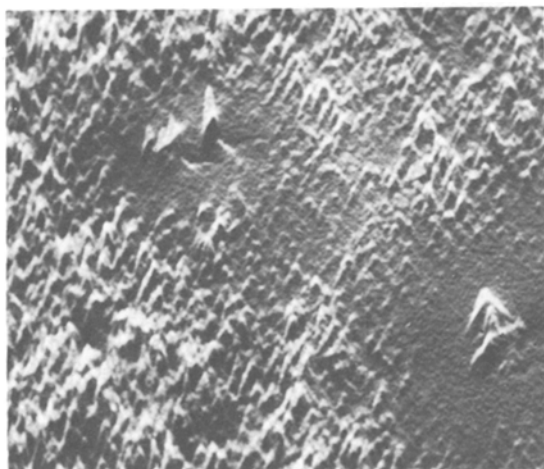

Figure 4 SEM (Y-Z, 34° tilt) of the cadmium film showing the initial nucleation stage (X 2800).

References

1. YU F. KOMNIK and E. I. BUKHSHTAB, *JETP Letters* 6 (1967) 58.
2. L. S. PALATNIK and V. M. KOSERICH, *Kristallogr.* 3 (1958) 709.
3. L. S. PALATNIK and YU F. KOMNIK, *Sov. Phys. Doklady* 5 (1960) 1072.

Received 18 October 1978
and accepted 31 May 1979

S. K. BANDYOPADHYAY

A. K. PAL

Department of General Physics and X-rays,
Indian Association for the Cultivation
of Science,
Calcutta 700032,
India

G. L. MALHOTRA

National Physical Laboratory
New Delhi,
India

Glass fibres containing metallic granules

Oxide glasses containing dispersed metallic granules of dimensions of the order of a few hundred angstroms show electrical conduction by an electron tunnelling mechanism between the metallic islands [1, 2]. It is therefore likely that electroconducting glass fibres can be made by inducing in them a microstructure similar to the above. There is also the possibility of obtaining glass fibres with improved mechanical properties by this method. In this communication we describe the results obtained on some glass fibres containing a dispersion of metallic particles.

The compositions of glasses used are given in Table I. These were arrived at by a trial and error method to ensure the twin requirements of proper microstructure and the liquidus temperature versus viscosity relation necessary for continuous fiberizing. The glasses were prepared from reagent-grade chemicals in 100 g batches. Ag_2O and B_2O_3 were introduced in the form of Ag_2SO_4 and H_3BO_3 ,

respectively, and the rest of the components as their oxides. The mixtures were at first heated slowly in the range 600 to 1100°C in high-density alumina crucibles in an electrically heated furnace. The final melting was carried out in the range 1300 to 1400°C for a period of $\frac{1}{2}$ h. This schedule was followed to ensure a homogeneous glass with less loss of Ag_2O [3]. The molten glass was cast in an aluminium mould. Glass frit obtained was remelted and fiberized using a single-orifice bushing made of pure alumina [4] which was mounted in a furnace having silicon carbide rods as heating elements. A typical fiberization temperature was ~1100°C. Continuous glass filaments were drawn onto a rotating drum at a surface speed of 4500 ft min^{-1} . The diameters of the glass fibres obtained varied between 10 and 12 μm . Fibres drawn from glasses 2, 3 and 4, respectively, have a microstructure consisting of metallic silver and/or bismuth particles (depending on the starting composition) of diameters ranging from 100 to 500 Å dispersed in a glass matrix. A typical transmission electron

TABLE I Compositions of glasses (mol %) for drawing fibres

Glass no.	SiO_2	B_2O_3	K_2O	Al_2O_3	As_2O_3	Bi_2O_3	Ag_2O
1	46	28	11	9	2	0	0
2	46	25	11	9	1	0	4
3	46	23	11	9	2	0	6
4	51	25	11	5	1	3	4